

TWIN-PAK

Submittal

Style "TP"
Slope Top Enclosures
Copper/Aluminum &
Steel Element Ratings

Specification

ENCLOSURE:

STYLE : "TP"
OUTLET: Slope Louvered
Two-Piece
LENGTHS: 3' thru 8' in 1' Increments
MATERIAL 18 Ga. C.R.S. Std.
FINISH: Baked Powder

BACKPLATE:

TYPE: Partial Backplate
LENGTHS: 4' and 8' Only
MATERIAL: 20 Ga. Painted Std.

Note: Assembly includes all necessary components for complete assembly. Element is shipped in separate carton.

ELEMENT:

TYPE: Cu/Al (Mechanically Expanded)
LENGTHS: 2' thru 6' in 1' Increments.
One End Flared, Std.
See Catalog for Working Pressures.

ELEMENT:

TYPE: Steel (Mechanically Expanded)
LENGTHS: 2' thru 6' in 1' Increments.
 NPT Threads Both Ends (standard)
 Beveled Ends for Field Weld

BRACKETS: Bracket w/Brkt Mtd B.B. Hanger

ACCESSORIES: All overlapping, engage between backplate and wall at top. Bottom returns to wall, holes provided for fasteners.

GUARANTEED

WORKING PRESSURES:

3/4" CU - 218 PSI at temperatures up to 300°F
1" CU - 204 PSI at temperatures up to 300°F
1-1/4" CU - 194 PSI at temperatures up to 300°F
1-1/4" IPS - 660 PSI at temperatures up to 650°F
2" IPS - 405 PSI at temperatures up to 650°F

STEEL

ELEMENT DESIGNATION	NOMINAL PIPE SIZE	CRADLE	A MINIMUM	A MAXIMUM
ST-144	1-1/4" (32)	2	7-7/8" (200)	8-15/16" (227)
ST-243	2" (50)	1	7-5/8" (194)	8-3/4" (222)

TP-14

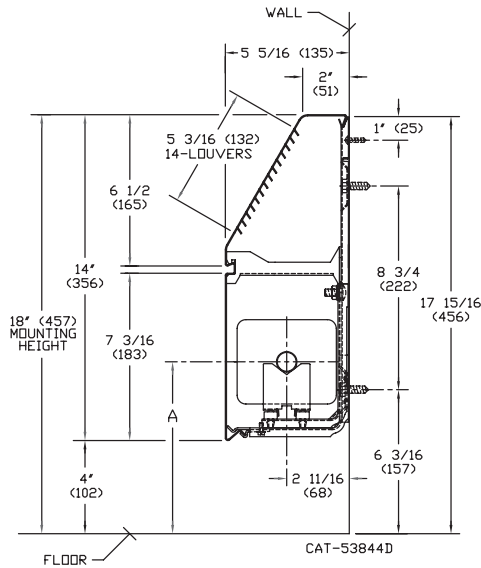

Note: Dimensions in "()" are shown in millimeters.

COPPER

ELEMENT DESIGNATION	NOMINAL PIPE SIZE	CRADLE	A MINIMUM	A MAXIMUM
STC-3/4 435	3/4" (20)	2	7-3/8" (187)	8-1/2" (216)
STC-435	1" (25)	2	7-1/2" (191)	8-5/8" (219)
STC-1435	1-1/4" (32)	2	7-5/8" (194)	8-13/16" (224)

TP-20

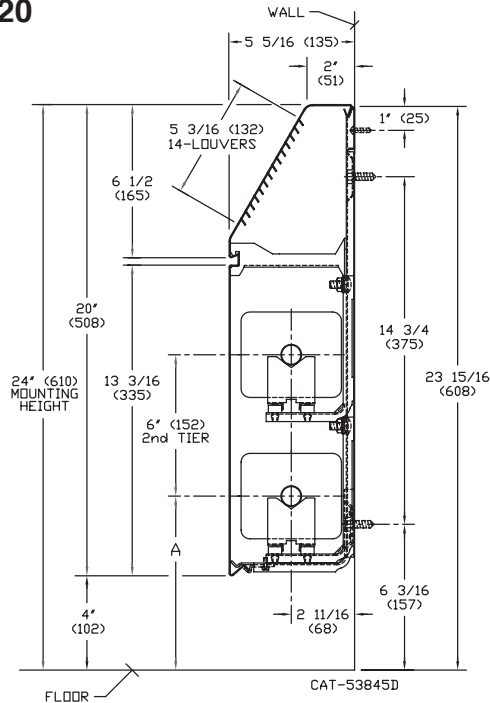

Beacon Morris
260 North Elm Street • Westfield, MA 01085
Tel: (413) 562-5423 • Fax: (413) 572-3764
www.beacon-morris.com

A MESTEK COMPANY



PROJECT: _____ DATE: _____

LOCATION: _____

ARCHITECT: _____

ENGINEER: _____

CONTRACTOR: _____

PO NUMBER: _____

STYLE "TP"

COPPER/ALUMINUM ELEMENT RATINGS

COVER	TUBE SIZE (IN INCHES)	CATALOG DESIGNATION	FIN SIZE (IN INCHES)	FIN PER FT.	FIN THICKNESS (IN INCHES)	ENCL DEPTH AND HEIGHT (IN INCHES)	TIERS AND CENTERS (IN INCHES)	MTG. HEIGHT (IN INCHES)	STEAM 215°F FACTOR	AVERAGE HOT WATER TEMPERATURE					
										200°F	190°F	180°F	170°F	160°F	150°F
										CORRECTION FACTORS					
TP-14	3/4	STC-3/4-435	4-1/4 x 3-5/8	50	.020	14B	1	18	1840	.86	.78	.69	.61	.53	.45
	1	STC-435	4-1/4 x 3-5/8	50	.020	14B	1	18	1930	1580	1440	1270	1120	980	830
	1-1/4	STC-1435	4-1/4 x 3-5/8	50	.020	14B	1	18	1860	1660	1510	1330	1180	1020	870
TP-20	3/4	STC-3/4-435	4-1/4 x 3-5/8	50	.020	20B	1	24	2090	1600	1450	1280	1130	990	840
	1	STC-435	4-1/4 x 3-5/8	50	.020	20B	1	24	2180	1800	1630	1440	1270	1110	940
	1-1/4	STC-1435	4-1/4 x 3-5/8	50	.020	20B	1	24	2130	1870	1700	1500	1330	1160	980
TP-20	3/4	STC-3/4-435	4-1/4 x 3-5/8	50	.020	20B	2	24	2820	2430	2200	1950	1720	1490	1270
	1	STC-435	4-1/4 x 3-5/8	50	.020	20B	2	24	2640	2160	2060	1820	1610	1400	1190
	1-1/4	STC-1435	4-1/4 x 3-5/8	50	.020	20B	2	24	2510	2270	1960	1730	1530	1300	1130

STYLE "TP"

STEEL ELEMENT RATINGS

COVER	TUBE SIZE (IN INCHES)	CATALOG DESIGNATION	FIN SIZE (IN INCHES)	FIN PER FT.	FIN THICKNESS (IN INCHES)	ENCL DEPTH AND HEIGHT (IN INCHES)	TIERS AND CENTERS (IN INCHES)	MTG. HEIGHT (IN INCHES)	STEAM 215°F FACTOR	AVERAGE HOT WATER TEMPERATURE					
										200°F	190°F	180°F	170°F	160°F	150°F
										CORRECTION FACTORS					
TP-14	1-1/4	ST144	4-1/4 SQ.	40	.032 A	14B	1	18	1570	.86	.78	.69	.61	.53	.45
	2	ST243	4-1/4 SQ.	32	.032 A	14B	1	"	1400	1350	1230	1080	960	830	710
TP-20	1-1/4	ST144	4-1/4 SQ.	40	.032 A	20B	1	24	1670	1300	1080	970	850	740	630
	2	ST243	4-1/4 SQ.	32	.032 A	20B	1	"	1450	1440	1300	1150	1020	890	750
TP-20	1-1/4	ST144	4-1/4 SQ.	40	.032 A	20B	2	"	2370	1250	1130	1000	890	770	650
	2	ST243	4-1/4 SQ.	32	.032 A	20B	2	"	2110	2040	1850	1640	1450	1260	1070

Guaranteed Working Pressures (PSI)

1-1/4" IPS: 660 @ temps. up to 650°F

2" IPS: 405 @ temps. up to 650°F

1-1/4" CU: 194 @ temps. up to 300°F

1" CU: 204 @ temps. up to 300°F

3/4" CU: 218 @ temps. up to 300°F

Maximum pressures at other temperatures are available upon request.

Hot Water Ratings shown are based on a constant velocity of 3 feet per second.

Installation Details

- Standard length: Available from 3' to 8' in 12" increments.
- When two or more enclosures occur in a run, a 4" wall sleeve is to be used at joints.

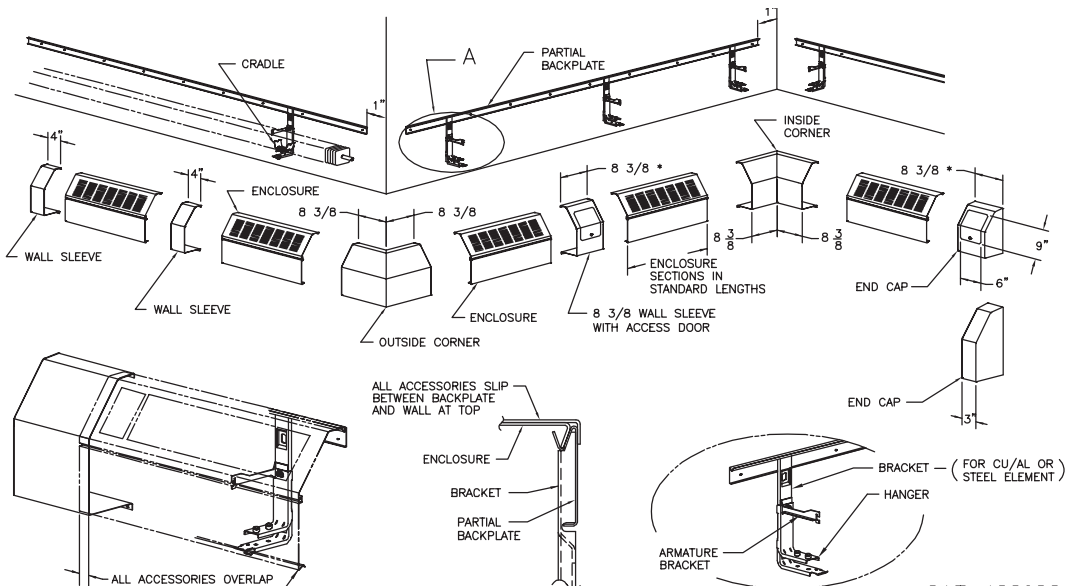

NOTE :

* MAX. OVERLAP OF ACCESSORY IS 7/8" WITH ACCESS DOOR

CAT-43303C